

LIGHTING PROFILES

ARSTYL® | WALLSTYL® | NOMASTYL®



NOËL & MARQUET
DESIGN ELEMENTS

INDEX

INFO

PRODUCT OVERVIEW	7
GLUE	11
GLUE CONSUMPTION	13
TOOLS	15
FINISH	19
INSPECTIONS INSTRUCTIONS	21

I • CORNICES

CORNICES GENERAL	
PREPARATION, CUTTING, INSTALLATION	1/2
CORNICES Z40 · Z41 · Z42 ARSTYL®	
CUTTING, REGULAR CORNERS, IRREGULAR CORNERS	1/6
CORNICE Z7 ARSTYL®	
FIX THE VARIO EXTENSION, INSTALLATION	1/7
SPECIAL CASES	
CORNICES IN A STAIRWEL	1/10
STEPPED WALL	1/11
EXPANSION JOINTS AND ANTI-VIBRATION ISOLATION JOINTS	1/12
HOLLOW JOINT	1/12
STOPPING A MOULDING	1/13

2 • CHAIR RAILS

CHAIR RAILS GENERAL	
PREPARATION, CUTTING, INSTALLATION	2/2
CURVES FOR CHAIR RAILS	
PREPARATION, CUTTING, INSTALLATION	2/5
SPECIAL CASE	
STOPPING A CHAIR RAIL	2/7

3 • SKIRTINGS

SKIRTINGS GENERAL	
PREPARATION, CUTTING, INSTALLATION	3/2
SPECIAL CASES	
STOPPING A SKIRTING	3/5

4 • FLEXIBLE PROFILES

ARSTYL® FLEX · WALLSTYL® FLEX	
RADIUS	4/2

5 • LIGHTING PROFILES

INDIRECT LIGHTING - CORNICES	
PREPARATION, CUTTING, INSTALLATION	5/2
CORNICES NOMASTYL® OR WALLSTYL®	
FOR INDIRECT LIGHTING	5/6
WT4 WALLSTYL(r) - COMPLEMENT	5/7
INDIRECT LIGHTING SKIRTINGS	
PREPARATION, CUTTING, INSTALLATION	5/8
LIGHTING PROFILES - FAQ	5/13

6 • DESIGN ELEMENTS

CEILING ROSES S ARSTYL® PREPARATION, INSTALLATION	6/2
R61 IN COMBINATION WITH Z61 PREPARATION, CUTTING, INSTALLATION	6/3
PILASTERS ARSTYL® PREPARATION, CUTTING, INSTALLATION	6/5
WALL PANELS ARSTYL® WALL PANELS PREPARATION, INSTALLATION	6/8
WALL TILES ARSTYL® WALL TILES VARIED AND CREATIVE WALL INSTALLATION OPTIONS	6/12
PREPARATION, INSTALLATION	6/12
SPECIAL CASES INSTALLATION ON A COMPLETE WALL	6/14

7 • FACADE DECORATION

WINDOW SILL PROFILE PREPARATION, ANGLED SECTION	7/2
ANGLED WINDOW SILL PROFILE	7/4
FRAME PROFILES	7/5
STRING COURSE	7/9
CUT IN THE PROFILE (DOWNPIPE)	7/9
KEY STONE	7/9
AREA OF THE ROOF OVERHANG AND PASSAGE	7/11
GABLE	7/12
STONES	7/13
CEILING ROSES	7/14
REPAIR OF DAMAGED PROFILES	7/15

This technical brochure has been prepared in accordance with the current state of our knowledge. We reserve the right to make modifications without prior notice. Without a written agreement to the contrary, our studies, descriptions, notices, advice or other technical documents concerning the functionality, behaviour or performance of goods are supplied as an indication only according to the common use of the goods under normal conditions of application, use and climate (moderate European regions), or those indicated to us by customers in writing. Save for the existence of fraud or gross negligence on our part, these studies, recommendations and other technical documents do not engage our liability. It is the customer's responsibility to check that they are suitable for the intended use.

INDIRECT LIGHTING CORNICES



Check lighting profiles for suitability of insert for indirect lighting. Select the profiles so that the luminaire is concealed and luminaires that produce heat have no direct contact with the profiles (min. 3 cm distance). If LED stripes are used, we recommend the use of LED aluminium rails.

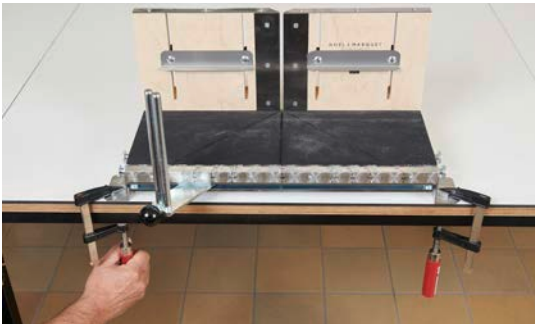

PREPARATION

- The VARIO mitre box can be fixed to the worktop or the staging with the existing aluminium brackets using two clamps (not included).



- Adjust the sliders of the mitre box to the height of the moulding or the side (distance between the bottom edge of the moulding and the ceiling).



- Determine the height of the moulding on the wall minus the distance of the top edge of the moulding to the ceiling (min. 8cm) on the wall. Mark the height of the moulding on the wall using a chalk line or a laser level.



Inner corner



Outer corner

- Measure the angle of the corner of the wall using the adjustable set-square.





- Place the adjustable set-square flat in the bottom of the mitre box, one side resting against the vertical part of the mitre box.
- Measure the distance between the two ends of the set-square.
- Divide this value by 2 and set the saw guide to the value obtained.
- Ensure that the saw passes through the middle of the adjustment screws, correcting the position as necessary.

The procedure applies to inner and outer corners (mitre).

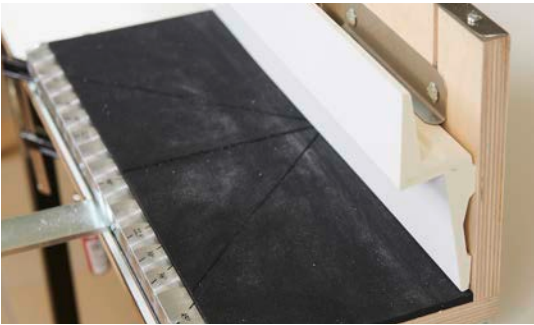

CUTTING

- Mitre cut the moulding using the appropriate saw:
 NOMASTYL®: PS saw
 ARSTYL®: HDPS/PU saw
 WALLSTYL®: HDPS/PU saw

INNER CORNER

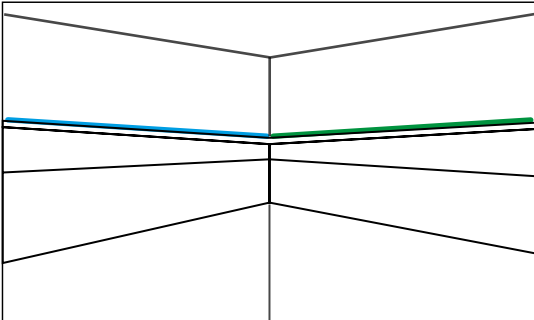

OUTER CORNER

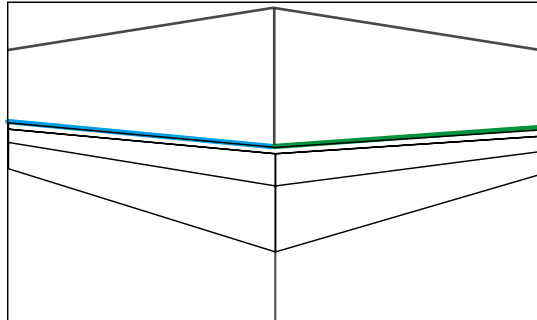

INNER CORNER LEFT

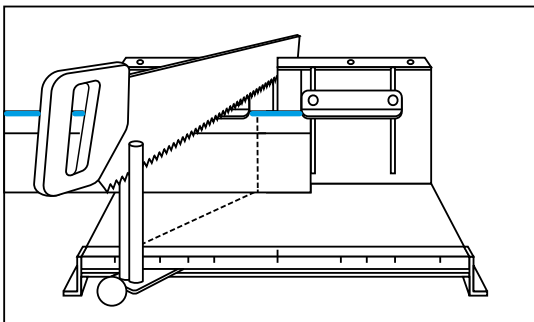

OUTER CORNER LEFT

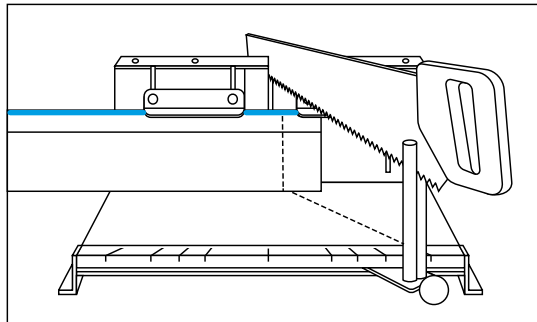

INNER CORNER RIGHT

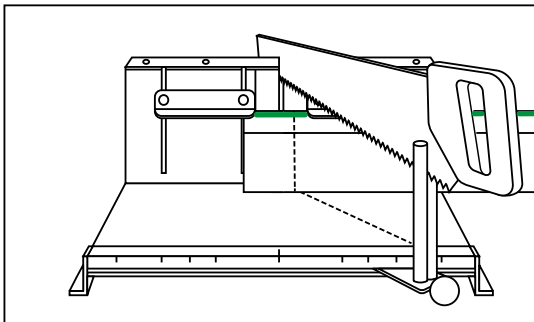

OUTER CORNER RIGHT

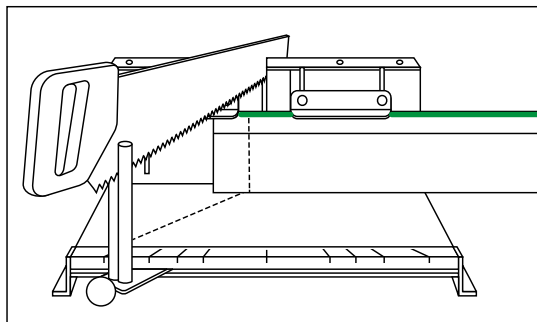



- Lightly sand the cut edges and the edges of the moulding with fine sandpaper (150 grit or less) or cutter and remove the sawdust with a damp sponge.



INSTALLATION

- Using a cartridge gun, generously apply the ADEFIX® PLUS adhesive in a continuous bead on gluing surfaces (see GLUE CONSUMPTION).



- Immediately install the cornices by pressing lightly (avoid finger pressure).
- Install the cornices so that the mitres and joints are flat and without offset (step).



- Apply ADEFIX® PLUS adhesive to the cuts and corner mitres so that it forms a 3 mm joint. The adhesive should not make a bead when the mouldings are pressed against one another. If necessary, the ADEFIX®PLUS adhesive can be removed cleanly with white spirit.



- Finish the adhesive joint with ADEFIX® adhesive.



- Remove excess glue, use a damp sponge or spatula if necessary.



- Smooth the joint with the NOËL & MARQUET painter's spatula.



- Leave to dry (min. 6h), then lightly sand the joints with emery paper (150 grit or finer). Make sure that the primer or film is not sanded down!



- Finish the wall joints as well as the mitre joints with ADEFIX® adhesive.



- Leave to dry (min. 6h). Apply the paint finish within 4 weeks (see FINISH) and install the LEDs.



CORNICES NOMASTYL® OR WALLSTYL® FOR INDIRECT LIGHTING



- If using a NOMASTYL® PLUS type moulding or WALLSTYL® (except IL3, IL4, IL10, IL11 or IL12), be sure to stick NMC reflective tape to the back (roll of reflexion tape: length 50 m x width 5 cm). This prevents the light shining through.
- The luminaires must not be placed inside, they must have their own mounting system, except for LED continuous rows or LED aluminium tracks with low heat generation <math><70^{\circ}\text{C}</math>.



To avoid the formation of cracks in the joints, you can cover the whole moulding with a fine non-woven fabric. Use an appropriate glue, for example Ovalit V.

WT4 WALLSTYL® - COMPLEMENT



- Before installing WT4, mark the position of the mounting clips on the wall, provide at least 2 clips per batten (included in delivery).



- Attach the clips to the wall.



- Apply a bead of ADEFIX® PLUS adhesive to the rear surface of the cornice (see GLUE CONSUMPTION).
- Slide the WT4 moulding WT4 onto the mounting clips; if necessary use nails, screws or additional points of hot glue. For further procedure, see INDIRECT LICHTING - CORNICES.

INDIRECT LICHTING SKIRTINGS

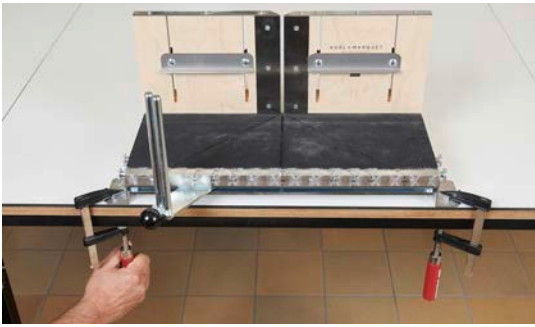

PREPARATION

- The VARIO mitre box can be fixed to the worktop or the staging with the existing aluminium brackets using two clamps (not included).



- Adjust the sliders of the mitre box to the height of the skirting or the side or take them off as they are not necessary for the cut of skirtings.



Inner corner



Outer corner

- Measure the angle of the corner of the wall using the adjustable set-square.



- Place the adjustable set-square flat in the bottom of the mitre box, one side resting against the vertical part of the mitre box.
- Measure the distance between the two ends of the set-square.
- Divide this value by 2 and set the saw guide to the value obtained.
- Ensure that the saw passes through the middle of the adjustment screws, correcting the position as necessary

The procedure applies to inner and outer corners (mitre).



CUTTING

- Place the skirting on the floor and mark the cut direction.



- Cut the skirting to size in the mitre box with the WALLSTYL® saw.

INNER CORNER

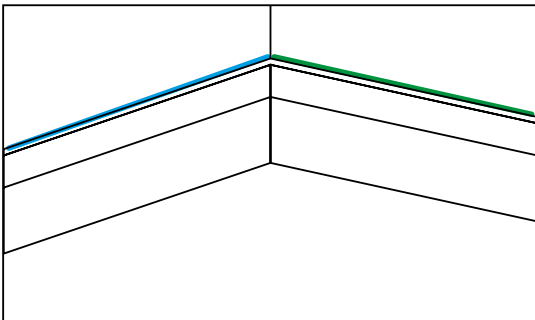

OUTER CORNER

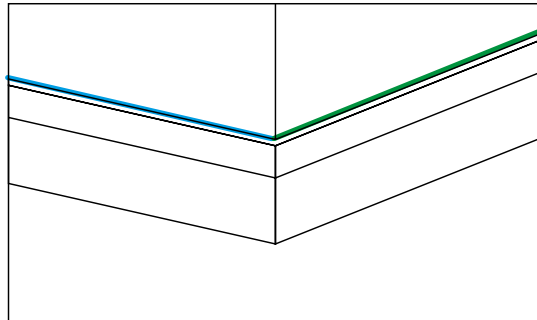

INNER CORNER LEFT

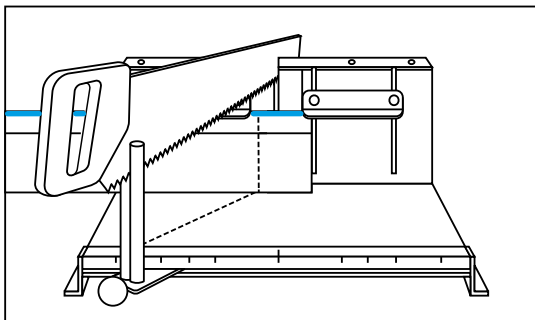

OUTER CORNER LEFT

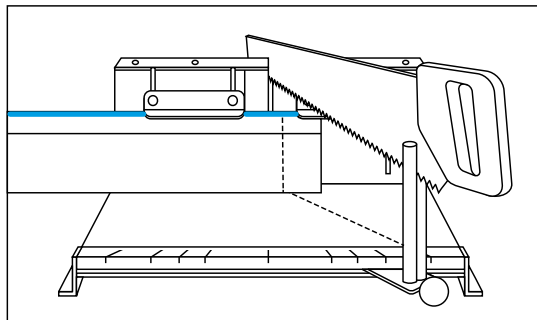

INNER CORNER RIGHT

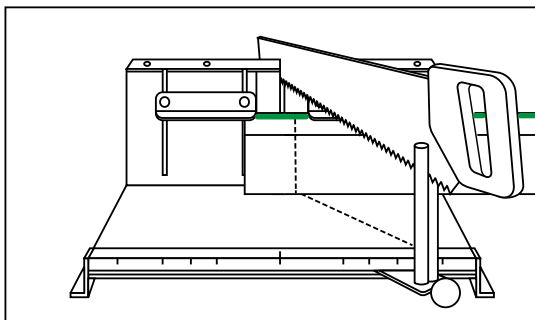

OUTER CORNER RIGHT

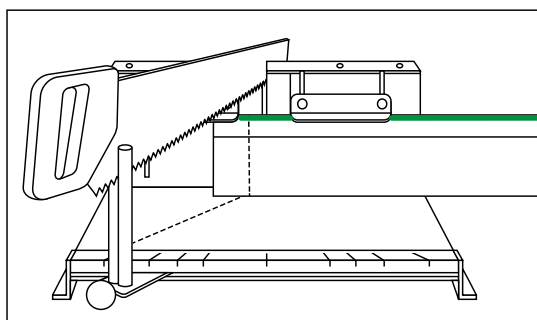



- When using an electric mitre saw, the blade must be suitable for synthetic materials. Cut at high speed.



Remove the LED diffuser before cutting (risk of splintering) and cut to size with a handsaw.



- At the connection joints, saw the profiles in 45° angles.



- Lightly sand the cut edges and the edges of the skirting with fine sandpaper (150 grit or less) or cutter and remove the sawdust with a damp sponge.



INSTALLATION

- Using a cartridge gun, generously apply the ADEFIX® adhesive in a continuous bead on the backside of the skirting (see GLUE CONSUMPTION).
- Use ADEFIX® PLUS as an adhesive for installation on non-absorbent substrates or in damp rooms.



- Immediately install the profiles by pressing lightly.
- Install the profiles so that the mitres and joints are flat and without offset (step).



- Remove excess glue, use a damp sponge or spatula if necessary.
- Smooth the joint with the NOËL & MARQUET painter's spatula.



- Apply ADEFIX® PLUS adhesive to the cuts and corner mitres so that it forms a 3 mm joint. The adhesive should not make a bead when the skirtings are pressed against one another. If necessary, the ADEFIX®PLUS adhesive can be removed cleanly with white spirit.



- Leave the glue to dry (min. 6 hours) then finish the joints and mitres with ADEFIX® adhesive.



- Leave to dry (min. 6h). Apply the paint finish within 4 weeks (see FINISH). The diffuser should be removed before painting.

- After drying, place LED stripes and diffuser.



The connection to the power supply must be carried out by a qualified electrician.



1. Which type of LED is recommended?

The choice of LED strips depends on the desired light colour, the desired light output and the place of use. Due to the numerous and rapid developments in the field of LED strips, we cannot make a recommendation for a specific LED strip.

2. Where to install the cable and driver?

Cable: There is enough space behind the profile

Driver: The location of the driver will depend on the size and shape of the driver and the lighting profile used. The ideal location must be determined in advance depending on the installation conditions.

3. What is the type of material and finishing of the diffuser?

ABS – OPAL

4. Punctual light prevention

The more LEDs per meter, the less light dots will be visible. The diffuser also provides uniform, indirect and glare-free light.

5. What is the maximum temperature?

The temperature resistance of the profile is +70°C, therefore the temperature of the LEDs must not exceed 70°C.

6. Is an aluminium rail or heat dissipation necessary?

With the low surface temperatures of LED technology, there is practically no infrared radiation. This is why the heat must be dissipated by heat dissipators to ensure optimum operation. Aluminium profiles or rails are recommended for this purpose.

The resulting heat build-up when not using the recommended heat dissipators can have a negative effect on the lifespan of the LEDs and the adhesive strength of the adhesive tapes.

Always follow the manufacturer's recommendations.

7. Who can make the electrical connection?

The connection must be carried out by a qualified electrician

8. Which drivers are suitable?

Suitable power supplies for LED strips are direct current sources (exact voltage in volts). The power of the driver must always be greater than the total power of the strip to be installed!

Example:

- LED: 9,6 W/meter
 - Total length: 5 meters
 - Power: $9,6 \times 5 = 48$ W, rounded = 50 W.
- ➔ Driver power: the driver should be selected with the next higher power, e.g. 70 W. Always observe the technical specifications of the LED strip.

9. How do I proceed with the corners?

For horizontal installation, LED strip systems should be used which offer easy connection angles. In this way, a uniform light pattern is also created in the corner area and mechanical damage to the strip light is avoided. Ready-to-use corners are also available for vertical installation.

10. Can the profiles be painted?

The visible sides of the profiles are primed and can therefore be painted (see FINISH). Please note for IL10/11/12 that the diffuser has to be removed before painting and that there are no edges/drops of paint in the area where the diffuser is attached to the profile. This could have a negative effect on the fixing of the diffuser.

11. Can I install the profiles in damp rooms?

The profiles are water-resistant. For the LEDs, depending on where you are going to install them, you will need to procure water resistant LEDs/drivers.

12. Which glue is recommended?

Please refer to our glue consumption tool available on our website: noel-marquet.com

We recommend to contact an electrician/LED manufacturer to ensure a safe and proper installation of the LEDs!

CONTACT

BENELUX

NMC SA / AG

Gert-Noël-Straße

B - 4731 Eynatten

T +32 87 85 85 00

F +32 87 85 85 11

info@nmc.eu

DEUTSCHLAND

NMC Deutschland GmbH

Weierhausstraße 8 b

D - 64646 Heppenheim

T +49 62 52 967 - 0

info@nmc-deutschland.de

FRANCE

NMC France sas

Z.I. de la Forêt

97, Route d'Anor - CS 10103

F - 59613 Fourmies Cedex

T +33 3 27 60 81 00

F +33 3 27 59 98 55

info@nmc-france.fr

UNITED KINGDOM

NMC UK Ltd.

Unit 1 East, Bridge Road

UK - Brompton on Swale – Richmond, DL10 7HS

T +44 1969 623410

F+44 1969 624398

sales@nmc-copley.co.uk

AUSTRIA

MAPA plus

Riedlerweg 15

T 0316 - 24 39 49

info@mapa.at

mapa.at

SWITZERLAND

Jules C. Binder SA

Z.I. du Moulin du Choc D

CH-1122 Romanel-sur-Morges

T +41 21 691 48 49

F +41 21 691 48 89

info@jules-c-binder.ch

